

Driver: Philippe Lachat Date: 18/05/08 Location: Morges (Switzerland)

Track:
 Size: Big Med. Small
 Grip: High Med. Low
 Surface: Bumpy Med. Flat

Engine:
 Type: RBC6 Plug: Turbo 7
 Exhaust: RB2045 Fuel: RV Revo
 Exhaust tuning: _____

FRONT

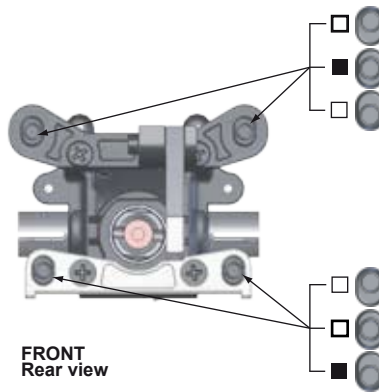
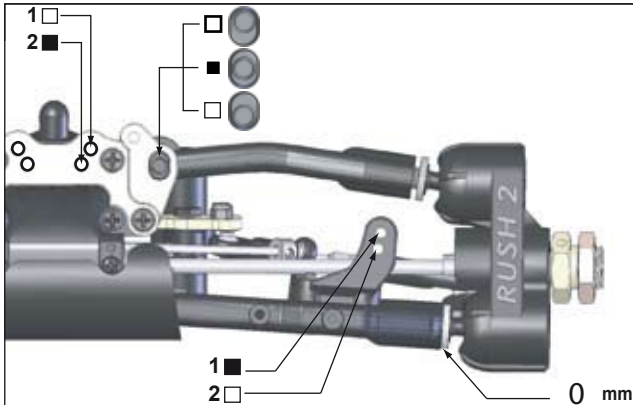

Front Shocks
 Oil: 450
 Piston: origin
 Spring: origin
 Clearance: 17 mm

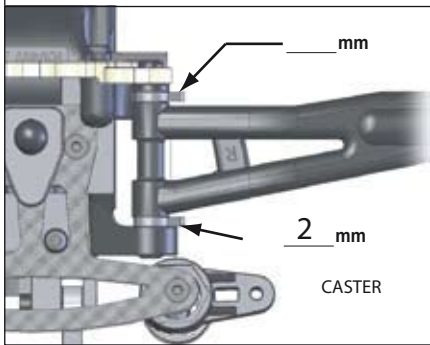

Maximum clearance: 48 mm
 Camber: 1°
 (at 20mm clearance)
 Toe out: 1°
 Anti Roll Bar:
 Yes: origin mm
 No:



Notes:
 Rear Spring Fioroni Orange
 10mm shorter

REAR

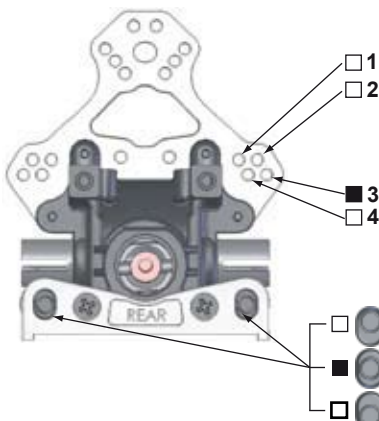
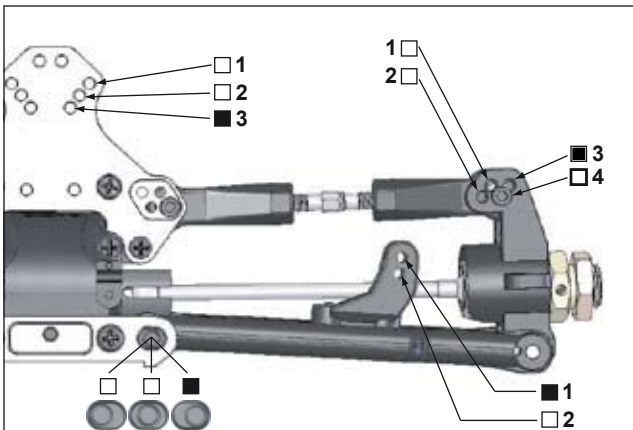

Rear Shocks
 Oil: 450
 Piston: origin
 Spring: Fioroni Orange
 Clearance: 21 mm

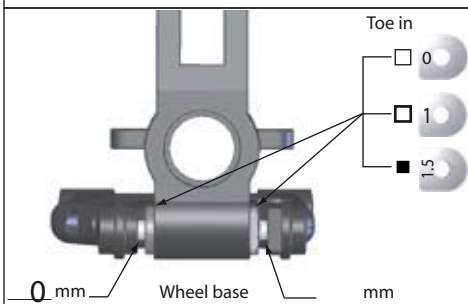

Maximum Clearance: 55 mm
 Camber: 4°
 (at 20mm clearance)
 Toe-in: _____
 Anti Roll Bar:
 Yes: 3 mm
 No:

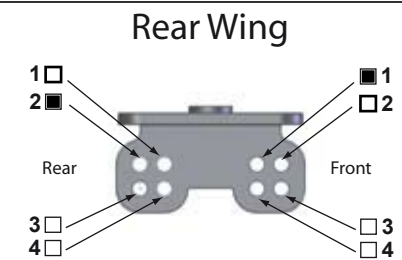

DIFFERENTIALS



Front: # 30 000 Centre: # 30 000 Rear: # 20 000