

Driver: Philippe Lachat Date: 24/04/08 Location: St Gallen (Switzerland)

Track:  
 Size:  Big  Med.  Small  
 Grip:  High  Med.  Low  
 Surface:  Bumpy  Med.  Flat

Engine:  
 Type: RBC6 Plug: Turbo 7  
 Exhaust: RB2045 Fuel: RV Revo  
 Exhaust tuning: \_\_\_\_\_

## FRONT

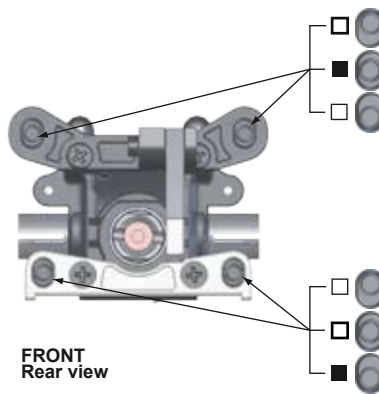
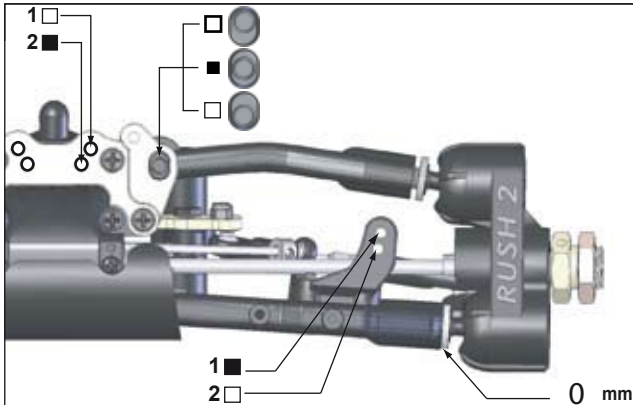

Front Shocks  
 Oil: 450  
 Piston: origin  
 Spring: origin  
 Clearance: 20 mm

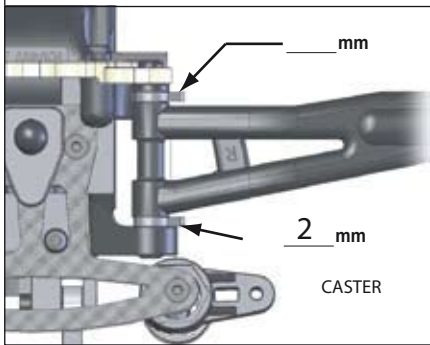

Maximum clearance: 48 mm  
 Camber: 1°  
 (at 20mm clearance)  
 Toe out: 1°  
 Anti Roll Bar:  
 Yes:  origin mm  
 No:



Notes:  
 Fioroni Clutch system \_\_\_\_\_  
 14T clutch bell \_\_\_\_\_

## REAR

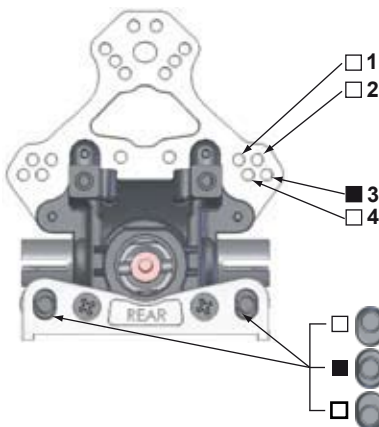
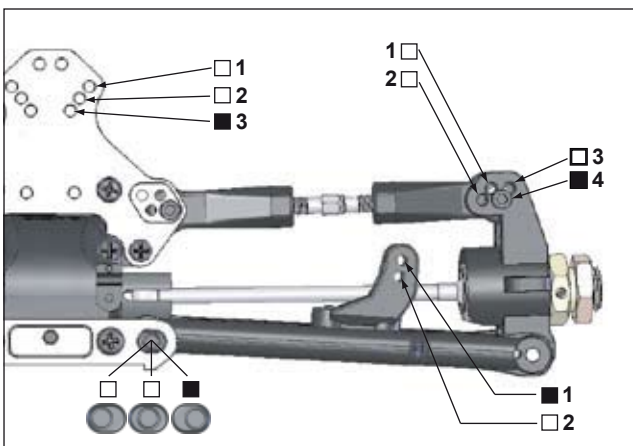

Rear Shocks  
 Oil: 450  
 Piston: origin  
 Spring: origin  
 Clearance: 24 mm

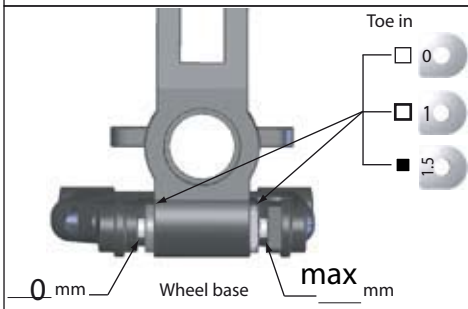

Maximum Clearance: 55 mm  
 Camber: 4°  
 (at 20mm clearance)  
 Toe-in: \_\_\_\_\_  
 Anti Roll Bar:  
 Yes:  3 mm  
 No:

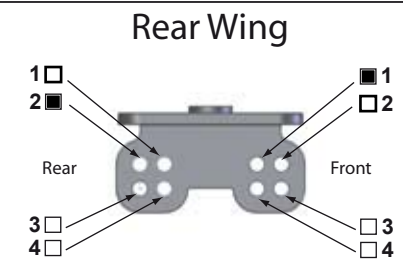

## DIFFERENTIALS



Front: # 20 000 Centre: # 20 000 Rear: # 10 000