

Driver: \_\_\_\_\_ Date: \_\_\_\_\_ Location: \_\_\_\_\_

**Track:**

Size:  Big  Med.  Small  
 Grip:  High  Med.  Low  
 Surface:  Bumpy  Med.  Flat

**Engine:**

Type: \_\_\_\_\_ Plug: \_\_\_\_\_  
 Exhaust: \_\_\_\_\_ Fuel: \_\_\_\_\_  
 Exhaust tuning: \_\_\_\_\_

**FRONT**

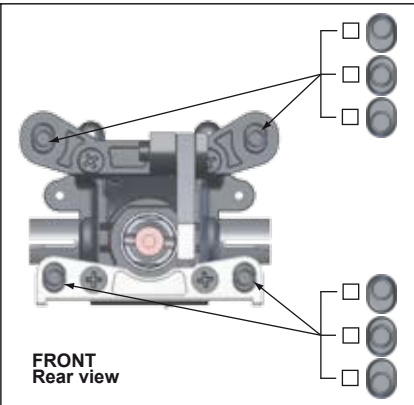
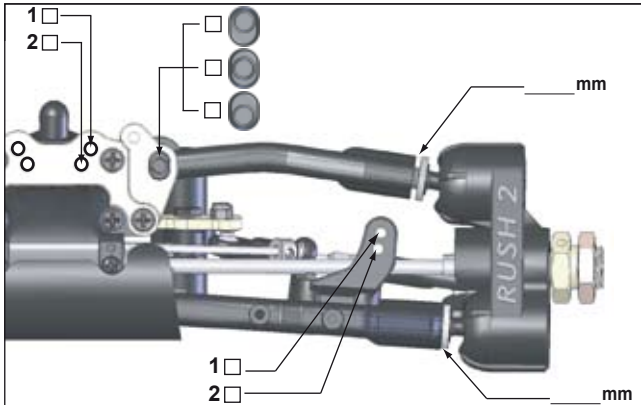

**Front Shocks**  
 Oil: \_\_\_\_\_  
 Piston: \_\_\_\_\_  
 Spring: \_\_\_\_\_  
 Clearance: \_\_\_\_\_ mm

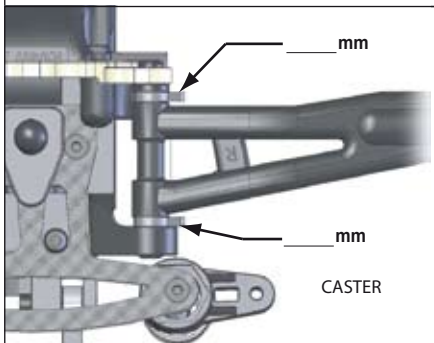

Maximum clearance: \_\_\_\_\_ mm  
 Camber: \_\_\_\_\_  
 (at 20mm clearance)  
 Toe out: \_\_\_\_\_  
 Anti Roll Bar:  
 Yes:  \_\_\_\_\_ mm  
 No:

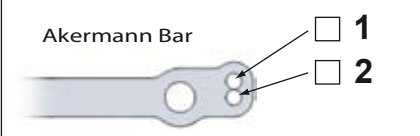

**Notes:**  
 \_\_\_\_\_  
 \_\_\_\_\_  
 \_\_\_\_\_

**REAR**

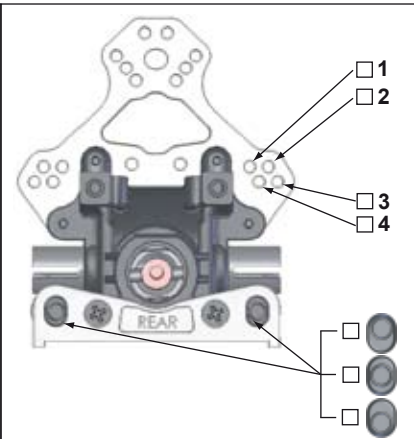
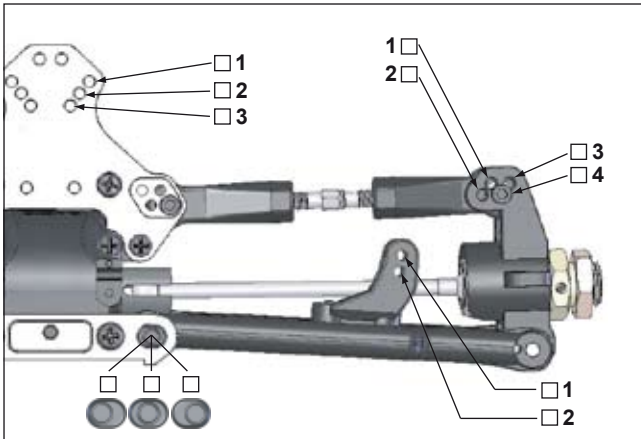

**Rear Shocks**  
 Oil: \_\_\_\_\_  
 Piston: \_\_\_\_\_  
 Spring: \_\_\_\_\_  
 Clearance: \_\_\_\_\_ mm

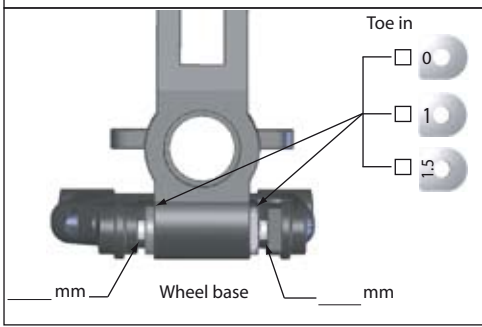

Maximum Clearance: \_\_\_\_\_ mm  
 Camber: \_\_\_\_\_  
 (at 20mm clearance)  
 Toe-in: \_\_\_\_\_  
 Anti Roll Bar:  
 Yes:  \_\_\_\_\_ mm  
 No:

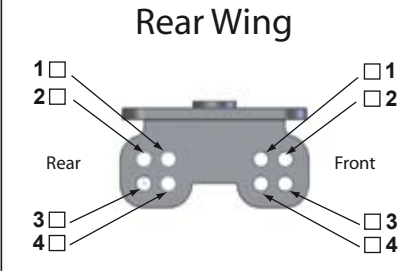

**DIFFERENTIALS**

Front: # \_\_\_\_\_ Centre: # \_\_\_\_\_ Rear: # \_\_\_\_\_